

Selbstfahrende Schneeschleuder, BNSF  
Self-propelled Xrotm Snow Blower, BNSF  
Chasse-neige automoteur Xrotm, BNSF

**Roco**

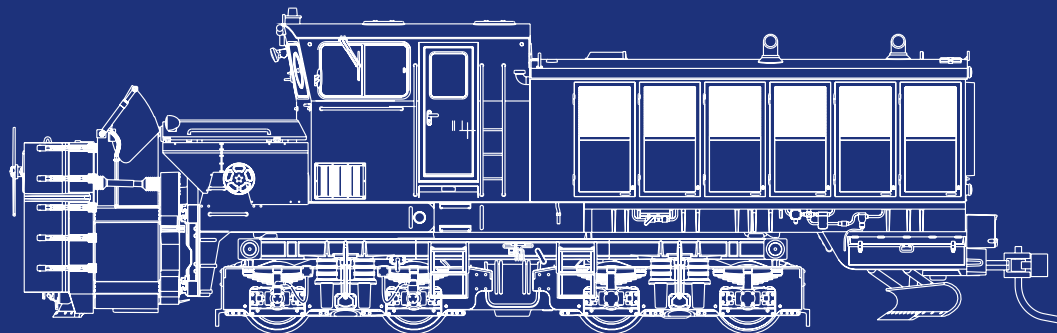

72806

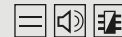

Handbuch

D

Manual

GB

Manuel

F

[www.roco.cc](http://www.roco.cc)

## Auspacken des Modells! / Unwrap model! / Déballage du modèle!

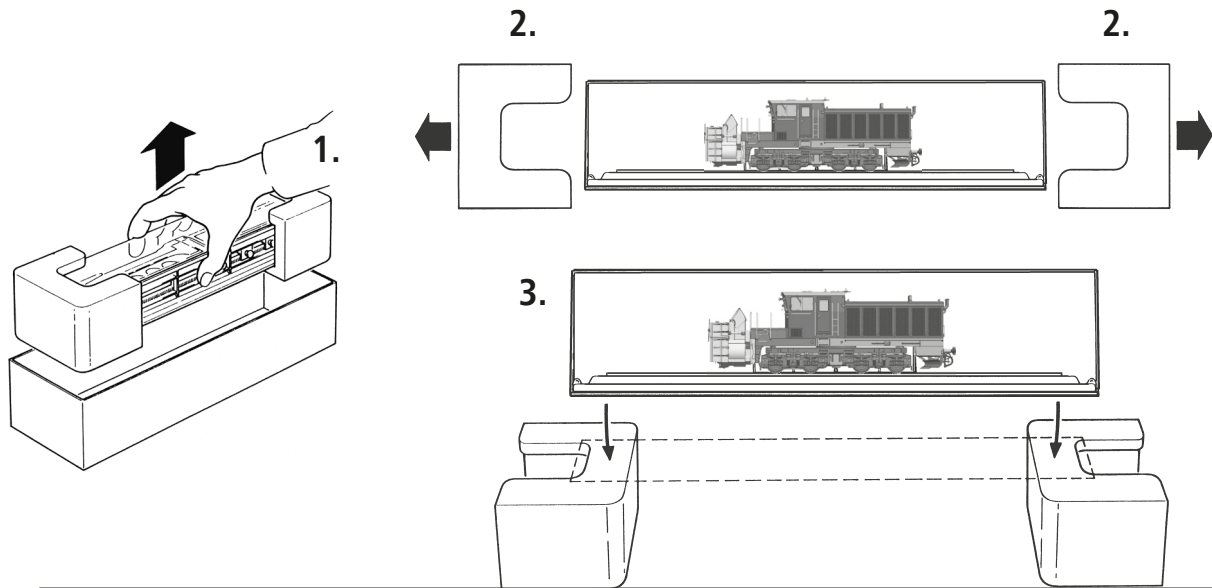

## Auspacken des Modells! / Unwrap model! / Déballage du modèle!

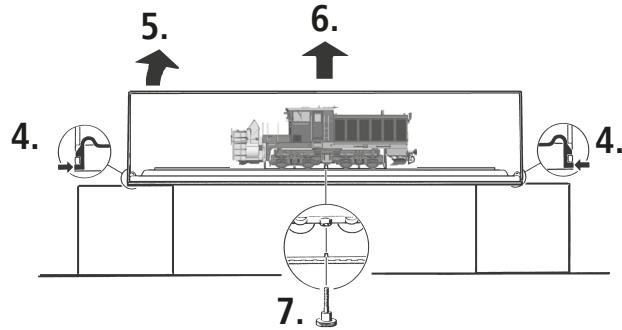

Vorsichtig herausheben !  
 Lift out carefully !  
 Soulevez avec précaution !  
 Sollevare con cautela !

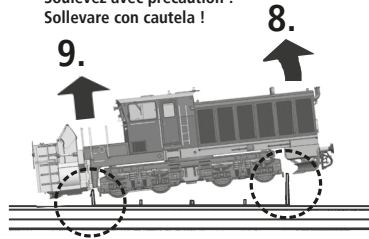

Beim Wiedereinpacken beachten !  
 Note when repacking !  
 Remarque lors de l'emballage !  
 Nota quando reimballaggio !

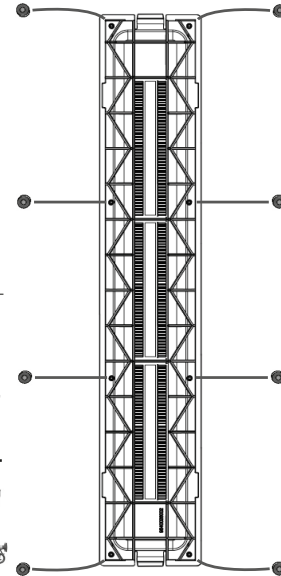
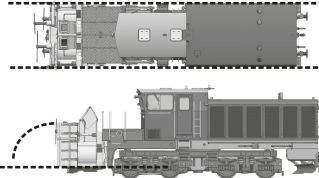



# Inhaltsverzeichnis

|          |   |         |   |         |
|----------|---|---------|---|---------|
| <b>D</b> | <b>Einleitung</b> .....                               | 5       | ■ Betrieb mit DCC-Zentrale (MULTIMAUS®) ..... | 16      |
|          |   |         | ■ Zusatzfunktion .....                        | 16      |
|          | <b>Inbetriebnahme ihrer Lokomotive</b>                |         | <b>Ersatzteilliste</b> .....                  | 46 – 53 |
|          | ■ Einfahren des Modells .....                         | 7       |   |         |
|          | ■ Betriebsbedingungen .....                           | 7       |   |         |
|          | <b>Wartung und Pflege Ihres Modells</b>               |         |   |         |
|          | ■ Reinigung der Radstromkontakte .....                | 8       |   |         |
|          | ■ Schmierung .....                                    | 9       |   |         |
|          | ■ Haftreifenwechsel.....                              | 10      |   |         |
|          | ■ Schleiferwechsel (nur für Wechselstrommodelle)..... | 10      |   |         |
|          | <b>Der Sounddecoder</b>                               |         |   |         |
|          | ■ Funktionstastenbelegung (Werkszustand) .....        | 11 – 12 |   |         |
|          | ■ Lokeinstellungen .....                              | 13      |   |         |
|          | ■ CV-Liste .....                                      | 14 – 15 |   |         |

---

## Zeichenerklärung

Gleichstrom mit Sound und Decoder



## Einleitung

D

### Lieber Modellbahnfreund,

mit seiner unglaublichen Feinmotorik zeigt das Modell, wie weit die Fertigung von Modelleisenbahn bereits entwickelt ist. Und der passende Sound fährt auch mit.

Das Spitzenmodell von Roco spielt in seiner Technik alle Stückchen: Die Schleudereinheit ist komplett heb- und senkbar. Die gesamte Fahrzeugbrücke kann sich um 180° drehen. Die Schleuderräder rotieren. Außerdem runden viele digital schaltbare Licht- und Soundfunktionen die Maschine im Maßstab 1:87 perfekt ab.

Wir wünschen viel Vergnügen und eine Gute Fahrt!  
Ihr Roco-Team

D

### Zum Vorbild

Die modernen dieselbetriebenen Schneeschleuder-Fahrzeuge wurden vom Unternehmen Beilhack in Bayern gebaut, das heute unter dem Namen Aebi-Schmidt-Holding firmiert. Der martialisch klingende Name „Beilhack“ hat eine lange Tradition im Schneeschleuder-Business und passt irgendwie zu den Maschinen mit ihren Vorschneidpropellern und scharfen Rafferblechen. Die Räumleistung liegt bei etwa 13.000 Tonnen Schnee in der Stunde. Der Vorteil der Beilhack-Schneeschleudern liegt in der einfachen Handhabung. So wird für den Betrieb kein zusätzliches Triebfahrzeug benötigt. Ein ebenso großer Vorteil ist, dass die Schneeschleuder selbstständig die Richtung wechseln kann, da der komplette Aufbau um 180 Grad drehbar ist.

Gut ein Dutzend Schneefresser dieser Leistungsklasse wurden seit der Produkteinführung in den 1980ern abgesetzt.



**Wichtiger Hinweis!** Dieses Modell ist mit einer Vielzahl von feinmechanischen und elektronischen Komponenten ausgestattet. Der evtl. Austausch von solchen Komponenten durch Ersatzteile und auch der Motorwechsel erfordern feinmechanische und elektrotechnische Kenntnisse!

Um Beschädigungen durch unsachgemäße Handhabung zu vermeiden, wenden Sie sich diesbezüglich an Ihren Roco-Fachhändler oder an eine Fachwerkstätte!

## Inbetriebnahme ihrer Lokomotive

D

### ■ Einfahren des Modells

Es empfiehlt sich, die Lok 30 Minuten vorwärts und 30 Minuten rückwärts ohne Belastung einlaufen zu lassen, damit Ihr Modell einen optimalen Rundlauf und beste Zugkraft bekommt.

### ■ Betriebsbedingungen

Der kleinste befahrbare Radius für dieses Modell ist **R2** (358 mm) des ROCO-Gleissystems.

Der einwandfreie Lauf Ihrer Lokomotive ist nur auf sauberen Schienen gewährleistet. Hierzu empfehlen wir den **ROCO-Schienenreinigungswagen Art. Nr. 46400** und bei etwas stärkerer Verschmutzung den **ROCO-Schienen-Reinigungsgummi Art. Nr. 10002**.

72806  





## Wartung und Pflege des Modells

**D** Damit Ihnen Ihre Lokomotive lange Freude bereitet, sind regelmäßig (ca. alle 30 Betriebsstunden) gewisse **Servicearbeiten** zweckmäßig.

### ■ Reinigung der Radstromkontakte

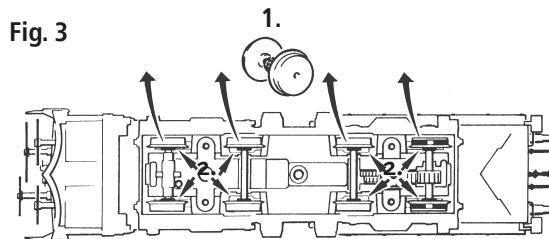
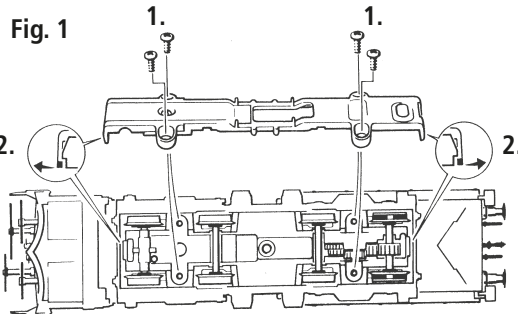
Radstromkontakte können auf unsauberen Schienen leicht verschmutzen. Bitte entfernen Sie vorsichtig mit einem kleinen Pinsel den Schmutz an den gekennzeichneten Stellen Fig.3. Dazu zuerst den Getriebedeckel abnehmen Fig. 1.



72806





## ■ Schmierung

Dazu zuerst den Getriebedeckel abnehmen (Fig. 1).  
 Versehen Sie die im Schmierplan Fig. 2 gekennzeichneten Stellen mit nur kleinen Öltropfen.

Wir empfehlen den **ROCO-Öler**  
 Art. Nr 10906.

Fig. 2

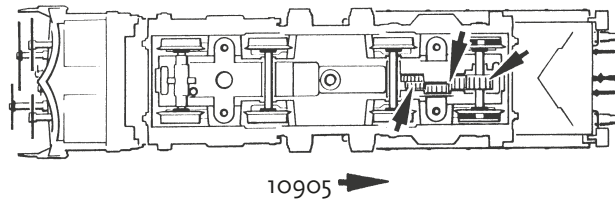
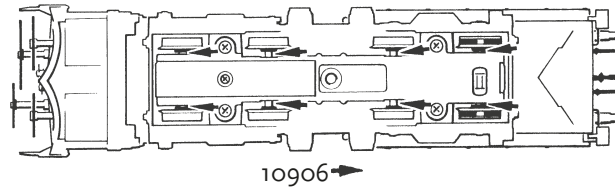

Zur Schmierung der Getriebeteile (Zahnräder, Schnecke) empfehlen wir das **ROCO-Spezialfett 10905**.  
 Im Falle der Schmierung diese Teile bitte nicht ölen.

D

72806

D

### ■ Haftreifenwechsel

Dazu zuerst den Getriebedeckel abnehmen (Fig. 1).

Danach den Radsatz herausnehmen und die Haftreifen mit einer Nadel oder mit einem feinen Schraubendreher abziehen (Fig. 4).

Beim Aufziehen der neuen Haftreifen darauf achten, dass diese sich nicht verdrehen.

72806

Fig. 4

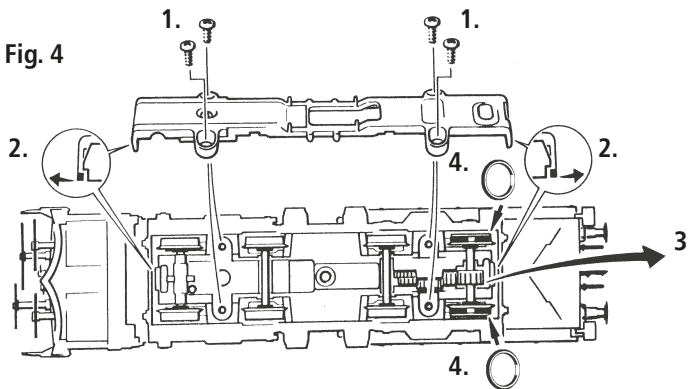

### ■ Schleiferwechsel (nur bei Wechselstrommodellen)

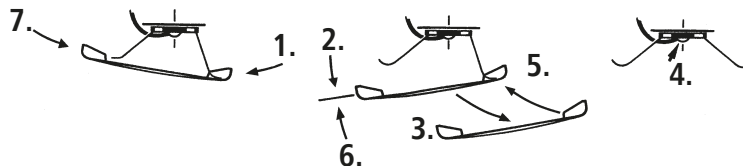

## Funktionen im Überblick

### ■ Funktionstastenbelegung der Schneeschleuder (Auslieferungszustand)

Die Lok ist ab Werk auf die Adresse 03 eingestellt

| F-Taste | Funktion           |
|---------|--------------------|
| F0      | Licht ein/aus      |
| F1      | Sound ein/aus      |
| F2      | Fräsen             |
| F3      | Fräskopf heben     |
| F4      | Aufbau drehen      |
| F5      | Horn               |
| F6      | Rangiergang        |
| F7      | Treppenbeleuchtung |
| F8      | Licht Warnsignal   |
| F9      | Ditch-Lights vorne |
| F10     | Horn               |
| F11     | Sanden             |
| F12     | Licht hinten       |

| F-Taste | Funktion  |
|---------|---|
| F13     | Kurvenquietschen<br>(nur mit F1 und<br>bei Fahrt) |
| F14     | Mute  |
| F15     | Lautstärke +                                      |
| F16     | Lautstärke -                                      |

 **Licht ROT  
ohne Funktion!**

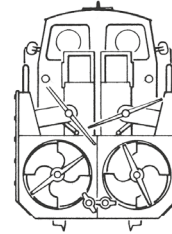

F0 Licht ein/aus

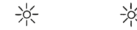

F9 Ditch-Lights

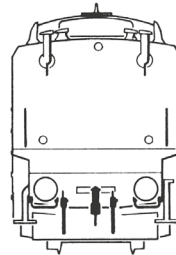

F12 Licht ein/aus



F8 Licht Warnsignal ein/aus



D

72806





D

F2 Fräsen

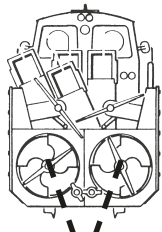

F2

F4 Drehen 180°

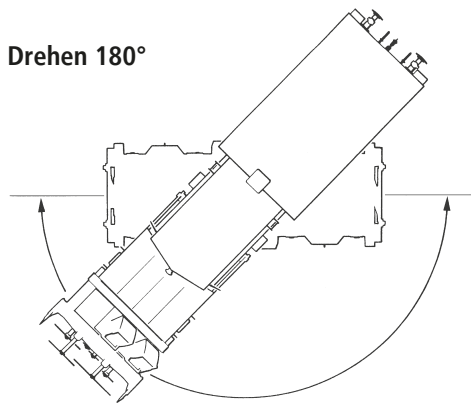

72806

F3 Fräskopf Heben und Senken

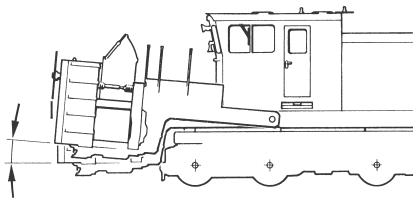

F7 Treppenbeleuchtung

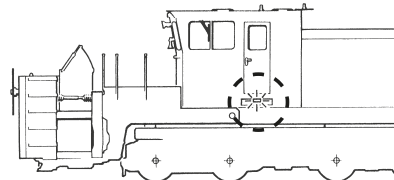

## Der Sounddecoder

### ■ Lokeinstellungen

Der in dieser Lok enthaltene Sounddecoder der Firma ZIMO wurde optimal auf die Lok eingestellt. Dennoch können Sie viele Decoder-Eigenschaften Ihren Wünschen anpassen. Dazu lassen sich bestimmte Parameter (die so genannten CVs – Configuration Variable – oder Register) verändern. Prüfen Sie aber vor jeder Programmierung, ob diese tatsächlich notwendig ist. Falsche Einstellungen können dazu führen, dass der Decoder nicht richtig reagiert.

Für einen hohen Fahrkomfort ist der Decoder werkseitig auf 28/128 Fahrstufen vorprogrammiert.

Damit ist er mit allen modernen DCC- (Z21® System / MULTIMAUS®) und Motorola®-Steuergeräten einsetzbar.



Der Sounddecoder wurde speziell für die zusätzlichen Funktionen verändert und darf nicht gegen einen im Handel erhältlichen Decoder ausgetauscht werden.



Soll die Lok umprogrammiert werden, darf nur die Lok auf dem Programmiergleis stehen.

D

72806



| CV        | Name  | Werte      | Default Werte |
|-----------|---|------------|---------------|
| 13        | <b>Analogmodus F1 bis F8</b> (00 – keine Funktion im Analogmodus)<br><b>01</b> – Funktion F1 <b>02</b> – Funktion F2 <b>04</b> – Funktion F3 <b>08</b> – Funktion F4<br><b>16</b> – Funktion F5 <b>32</b> – Funktion F6 <b>64</b> – <b>Funktion F7</b> <b>128</b> – Funktion F8<br><b>Achtung!</b> Beim Aktivieren von mehreren Funktionen über die CV's im Analogbetrieb, kommt es zur gleichzeitigen Ausführung | 00 – 255   | 1             |
| 14        | <b>Analogmodus F9 bis F12, sowie Stirnlicht</b><br><b>01</b> – Stirnlicht vorne   <b>02</b> – Stirnlicht hinten   <b>04</b> – Funktion F9   <b>08</b> – Funktion F10   <b>16</b> – Funktion F11<br><b>32</b> – Funktion F12   <b>64</b> – Analogbetrieb ohne Verzögerung möglich (CV3, CV4)   <b>128</b> – Analogbetrieb geregelt   | 00 – 255   | 195           |
| 17+<br>18 | <b>Lange Adresse</b> (Voraussetzung: In CV29 ist die lange Adresse eingeschalten)   | 100 – 9999 |               |
| 29        | <b>Einstellungen</b>  |            | 14            |
| 266       | <b>Gesamtlautstärke aller Geräusche</b>   | 00 – 255   | 55            |
| 287       | <b>Bremssoundschwelle</b> (Je größer der Wert, umso früher wird beim Bremsen das Bremsgeräusch gestartet)   | 00 – 255   | 20            |



## ■ Betrieb mit DCC-Zentrale (Z21® System / multiMAUS®)

D

Da die (MULTIMAUS®) über 20 Funktionstasten und einer Lichttaste verfügt, ist die Bedienung besonders komfortabel.

### Programmierarten

**Wir empfehlen:** Direkt CV-Programmierung (byteweise) oder POM-Modus (Programmierung am Hauptgleis). Das Programmieren ist im Handbuch der (MULTIMAUS®) beschrieben.

72806  
III  
II  
I

### Auslesen:

Mit einer entsprechenden Ausrüstung (z.B. / Z21® / z21® / z21® start) können Sie die Werte byte- und bitweise auslesen.

## ■ Zusatzfunktionen

Eine Fülle anderer, jedoch wohl recht selten benötigter Einstellmöglichkeiten hinsichtlich Fahrstufenkurve, Lastnachregelungseinstellung oder Geräuschsynchronisation können Sie im ausführlichen Handbuch in Erfahrung bringen. Bitte beachten Sie hierzu die Anleitung MX645P22 auf [www.zimo.at](http://www.zimo.at)





*Roco*

## Notizen / Notes

D







# Table of Content

GB

|  |         |  |         |
|--|---------|--|---------|
| <b>Introduction</b> .....                        | 19      | ■ Operation with a DCC Command Station<br>(Z21® system / MULTIMAUS®) ..... | 30      |
| <b>Starting locomotive operation</b>             |         | ■ More Functions .....   | 30      |
| ■ Running the model in .....                     | 21      | <b>Replacement parts</b> .....   | 46 – 53 |
| ■ Operating instructions .....                   | 21      |  |         |
| <b>Maintenance of the model</b>                  |         |  |         |
| ■ Cleaning of wheel contact .....                | 22      |  |         |
| ■ Lubrication .....                              | 23      |  |         |
| ■ Replacement of traction tyres .....            | 24      |  |         |
| ■ AC pick up (only for AC models) .....          | 24      |  |         |
| <b>The Sounddecoder</b>                          |         |  |         |
| ■ function key allocation (delivery state) ..... | 25 – 26 |  |         |
| ■ Locomotive Settings .....                      | 27      |  |         |
| ■ CV- list .....                                 | 28 – 29 |  |         |

---

## Signs & symbols

   Direct current with sound and decoder





## Introduction

**Dear Model Railway Fan,**

with its unbelievable fine motor technology, the model shows how far the production of model railways has already developed; and the right sound travels with it.

The top model from Roco leaves nothing to be desired when it comes to its technology. The blower unit can be fully raised and lowered. The entire vehicle bridge is rotatable by 180°. The blower wheels rotate and the 1:87 scale machine is perfectly rounded off by numerous switchable light and sound functions.

We wish you hours of pleasure and a good journey!

Your Roco Team



GB

## The Original

The modern diesel-powered snow throwers were built by the company Beilhack in Bavaria, which today operates under the name Aebi-Schmidt-Holding. The martial-sounding name „Beilhack“ has a long tradition in snow plowing business and somehow fits in with the machines with their pre-cutting propellers and sharp rebar sheets. The clearing capacity is about 13,000 tons of snow per hour. The advantage of the Beilhack snow throwers lies in their easy handling. So no additional traction vehicle is needed for the operation. An equally great advantage is that the snow thrower can change direction on its own since the complete body can be rotated 180 degrees. Well over a dozen snow-goers in this performance class have been discontinued since the product launch in the 1980's.



**Important Instructions!** The motor of this model is tightly installed due to the construction.

The motor changing requires knowledge of precision mechanics and electrical engineering!

Please contact your Roco stockist or a specialised workshop in this regard in order to avoid damage being caused by incorrect handling!

## ■ Running the model in

Before use advisable to let the loco go around about 30 forwards and 30 minutes backwards without load, to obtain an optimal circuit and best tractive powermalen Rundlauf und beste Zugkraft bekommt.

GB

## ■ Operating instructions

The smallest radius this model should run is R2 (358 mm) of the ROCO track system (model without tubes protecting pistons).

Your locomotive will run smoothly on clean tracks only. For this purpose we recommend using item no. **46400, Roco track cleaning van**, or item no. **10002, Roco track cleaning rubber**, for removing heavy dirt.

72806  
GB



## Maintenance of the model

**GB** In order to ensure that your locomotive provides you with many years of pleasure, certain service work at regular intervals (approx. every 30 operating hours) is advisable.

72806

### ■ Cleaning of wheel contacts

Wheel contacts easily get dirty on tracks which are not entirely clean. Use a small brush to **remove dirt** fom spots marked in fig. 3. Remove the gear cover (fig. 1).

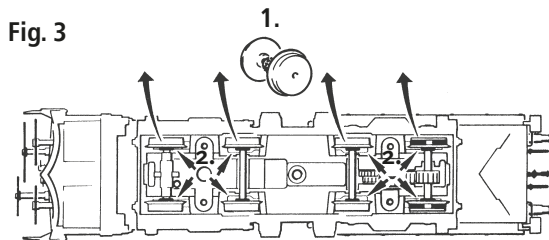
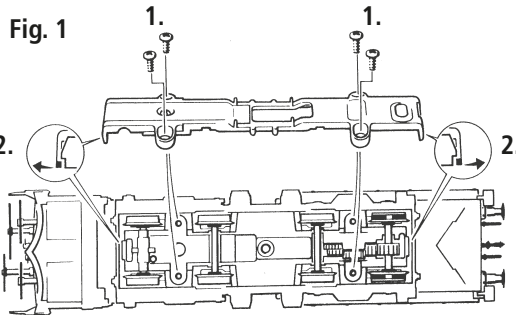

## ■ Lubrication

Remove the gear cover (fig.1).  
Apply tiny oil drops to spots marked (fig.2.)

We recommend **ROCO oiler Art. No. 10906.**

Fig. 2

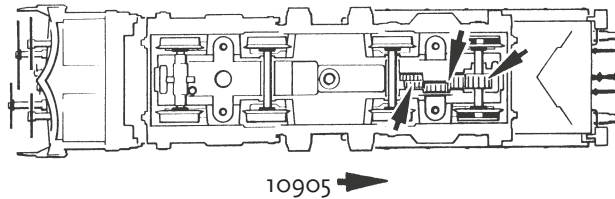
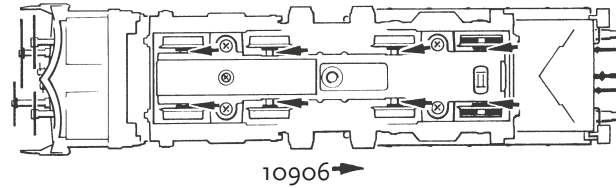

In order to lubricate the transmission parts (gear wheel, screw), we recommend using **ROCO special grease 10905.** If lubricated, do not oil these parts.

GB

72806



### ■ Replacement of traction tyres

GB

Remove the gear cover (fig. 1).  
Take out wheel set and remove traction tyre using a pin or a fine screwdriver (fig. 4.)

When applying the new traction tyres, please ensure that they do not rotate.

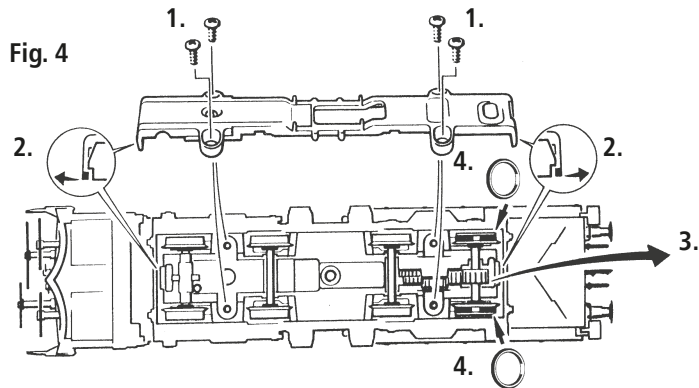

72806

### ■ AC pick up (only for AC models)

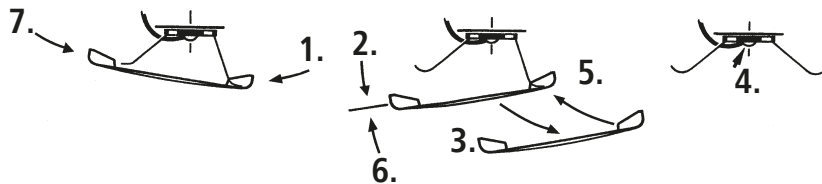



## Functions at a Glance

### ■ Function key allocation

The factory-set defaults address of the lok is 03.

| F-Key | Function            |
|-------|---------------------|
| F0    | Lights on/off       |
| F1    | Sound on/off        |
| F2    | Mill                |
| F3    | Raise mill          |
| F4    | Rotate body         |
| F5    | Horn                |
| F6    | Shunting mode       |
| F7    | Step lighting       |
| F8    | Warning signal lamp |
| F9    | Ditch-Lights front  |
| F10   | Horn                |
| F11   | Sanding             |
| F12   | Rear lights         |

| F-Key | Function  |
|-------|---|
| F13   | Curve squeaking<br>(only with F1 and<br>whilst driving) |
| F14   | Mute  |
| F15   | Volume +  |
| F16   | Volume -  |

 **RED lights  
without function!**

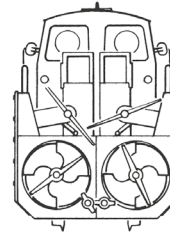

F0 Lights on/off



F9 Ditch-Lights

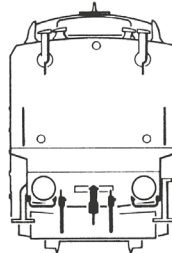

F12 Lights on/off



F8 Warning signal lamp





GB

F2 Mill

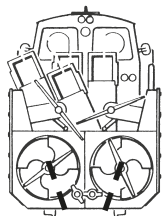

F2

F4 Rotate body 180°

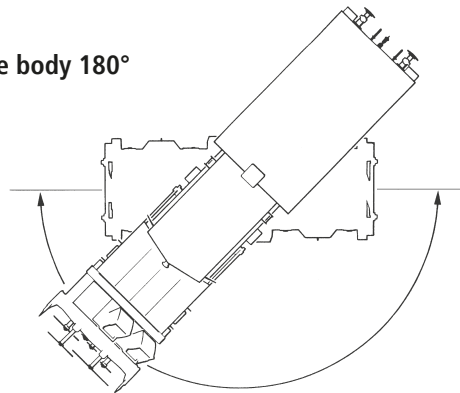

72806

F3 Raise mill

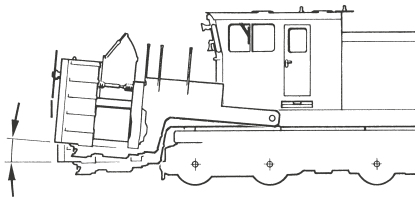

F7 Step lighting

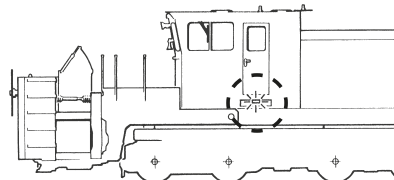

## The Sounddecoder

### ■ Locomotive Settings

The Sounddecoder has been optimally adjusted to this locomotive. You can still adapt numerous decoder properties to your wishes however. Certain parameters (referred to as CVs – Configuration Variable – or register) can be amended.

Please check before each programming if this is really necessary. Incorrect settings can result in the decoder not reacting correctly.

The decoder is preprogrammed with 28/128 speed steps at the factory for a high level of comfort. This means that it can be used together with all of the modern DCC (Z21® / z21® / z21® start) and Motorola® control devices.

GB

72806  

The Sounddecoder has been especially modified for the additional functions and must not be replaced with a decoder which is available from a retailer.



If the locomotive is to be reprogrammed, only the locomotive is to be on the programming track

## ■ CV-list

GB

72806

| CV | Name  | Werte    | Default Werte |
|----|---|----------|---------------|
| 1  | <b>Adresse</b> (= short address)  | 01 – 99  | 3             |
| 2  | <b>Minimum speed</b> (lowest creeping speed)  | 01 – 255 | 4             |
| 3  | <b>Start-up delay</b> (from standstill to maximum speed)  | 00 – 255 | 12            |
| 4  | <b>Braking delay</b> (from maximum speed to stand-still)  | 00 – 255 | 14            |
| 5  | <b>Maximum speed</b>  | 00 – 255 | 255           |
| 6  | <b>Medium speed</b> (at medium running step)<br>Value 1 corresponds to 1/3 of Vmax. (CV 5)  | 00 – 252 | 1             |
| 7  | <b>Decoder Version Number</b> (only read! Readable only on reading-capable amplifiers/centres).<br><b>Important!</b> Please note when using the Z21 / multiMAUS in order to achieve CVs greater than CV255: when undertaking a short-term programming of CV7, only the subsequent programming access with the value 10 is increased by 100 CV places (meaning CV166 then accesses CV266 for example). The value 20 is increased by 200 CV places. |          |               |
| 8  | <b>Resetting of all values to the default settings</b><br>(With readable amplifiers/controllers, the manufacturer ID is readable)   |          | 08 = Reset    |

| CV        | Name   | Value      | Default Value |
|-----------|--|------------|---------------|
| 13        | <b>Analogue modes F1 - F8</b> (00 – no function in analogue mode)<br>01 – Function F1      02 – Function F2      04 – Function F3      08 – Function F4<br>16 – Function F5      32 – Function F6      64 – <b>Function F7</b> 128 – Function F8<br>Attention! Several things happen at the same time when several functions are activated via CV's in analogue operation. | 00 – 255   | 1             |
| 14        | <b>Analogue modes F9 - F12</b><br>01 – Front light   02 – Rear light   04 – Funktion F9   08 – Function F10   16 – Function F11<br>32 – Function F12   | 00 – 255   | 195           |
| 17+<br>18 | <b>Long Adresse</b> (requirement: corresponding CV29 long address setting is activated)  | 100 – 9999 |               |
| 29        | <b>Settings</b>  |            | 14            |
| 266       | <b>Total Volume of all Sounds</b>  | 00 – 255   | 55            |
| 287       | <b>Braking Sound Threshold</b> (The higher the value, the earlier the braking sound starts when braking.)  | 00 – 255   | 20            |





## ■ Operation with a DCC Command Station (Z21® system / multiMAUS)

As the MULTIMAUS® has 20 function keys and a light button, can be especially comfortably operated.

GB

### Programming modes:

The locomotive and carriages react to all DCC programming modes.

**We recommend:** direct CV programming (byte by byte) or POM mode (programming on main track).

The programming is described in the MULTIMAUS® manual.

### Reading CVs:

With the appropriate equipment (e.g. / Z21® / z21® / z21® start), you can read the value byte by byte and bit by bit.

72806

## ■ More Functions

You can find out about a range of other possible settings, which are probably very rarely needed, relating to drive speed curve, load control setting or noise synchronization from the detailed handbook. This can be downloaded as a pdf document MX645P22 from [www.zimo.at](http://www.zimo.at).





## Notizen / Notes

GB

Five horizontal grey bars intended for taking notes, separated by thin black lines.





## Table des matières

|          |   |         |   |         |
|----------|---|---------|---|---------|
| <b>F</b> | <b>Introduction</b> .....                               | 33      | ■ <b>Fonction complémentaire</b> .....    | 44      |
|          | <b>Mise en service de votre locomotive</b>              |         | <b>Liste des pièces de rechange</b> ..... | 46 – 53 |
|          | ■ Rodage du modèle .....                                | 35      |   |         |
|          | ■ Précautions d'exploitation .....                      | 35      |   |         |
|          | <b>Maintenance et entretien du modèle</b>               |         |   |         |
|          | ■ Nettoyage des contacts d'alimentation des roues ..... | 36      |   |         |
|          | ■ Lubrification .....                                   | 37      |   |         |
|          | ■ Changement des pneus superadhérents .....             | 38      |   |         |
|          | ■ Fotteur pour Systeme AC .....                         | 38      |   |         |
|          | <b>Le décodeur</b>                                      |         |   |         |
|          | ■ Affectation des touches de fonction .....             | 39 – 40 |   |         |
|          | ■ Réglages de la locomotive .....                       | 41      |   |         |
|          | ■ Liste CV .....  | 42 – 43 |   |         |
|          | ■ Système avec centrale DCC (MULTIMAUS®) .....          | 44      |   |         |

---

### Signes et symboles

   Courant continu avec son et décodeur





## Introduction

F

### **Cher amateur de modélisme ferroviaire,**

grâce à son incroyable motricité fine, le modèle montre à quel point la production est avancée dans le modélisme ferroviaire.

Sans oublier le bruitage assorti dont l'article est équipé.

Le modèle de pointe de Roco comble tous les désirs au niveau technique : l'unité de déneigement peut être entièrement levée et descendue. Le pont du véhicule peut tourner sur 180°. Les roues tournent. Par ailleurs, de nombreuses fonctions d'éclairage et de bruitage, numériquement commutables, complètent parfaitement la machine à l'échelle 1:87.

Amusez-vous bien et bonne route !

L'équipe Roco

F

## La Beilhack

Les véhicules chasse-neige diesel modernes ont été construits en Bavière par l'entreprise Beilhack, connue aujourd'hui sous le nom Ae-bi-Schmidt-Holding. Quelque peu martial, le nom « Beilhack » a une longue tradition dans le secteur des chasse-neige et s'harmonise d'une certaine façon avec ces machines, leurs hélices de précope et leurs tôles de ramassage coupantes. Leur capacité de déblaiement est d'environ 13 000 tonnes de neige par heure. Un des avantages des chasse-neige Beilhack réside dans leur manipulation aisée. Ils n'ont pas besoin de véhicule-moteur.

Un autre est leur capacité à pouvoir changer de direction de façon autonome, leur structure pouvant complètement pivoter à 180°.

Une bonne douzaine d'avaleurs de neige de cette catégorie de puissance ont été utilisés depuis leur introduction sur le marché dans les années 80.

### INFORMATION IMPORTANTE !

Le moteur de ce modèle est de conception étroitement équipée.

Changer le moteur exige des connaissances en électronique et en mécanique de précision!

Afin d'éviter tout endommagement suite à une manipulation in correcte, adressez- vous à votre commerçant spécialisé Roco ou à un atelier spécialisé.

## Mise en service de votre locomotive

### ■ Rodage du modèle

Afin d'assurer les meilleures conditions de marche tranquille et de traction puissante à votre modèle nous vous conseillons un rodage du modèle de 30 minutes environ en marche avant et d'autres 30 minutes en marche arrière. Pendant cette période la marche doit se faire »haut le pied«.

### ■ Précautions d'exploitation

Le rayon minimal admissible du modèle present est fixé à soit 358 mm, soit le rayon **R2** des voies ROCO (sans des tignes de piston!) Une marche impeccable de votre modèle n'est réalisable que sur des voies vraiment propres. A ces fins nous vous recommandons notre **wagonnettoyeur Roco réf. 46400** ou - en cas d'un encrassement plus considérable de la voie - notre **gomme de nettoyage ROCO réf. 10002**.

F

72806  





## Entretien préventif du modèle

F

Pour garantir un fonctionnement impeccable de votre modèle au fil de longues années veuillez assurer régulièrement (environ tous les 30 heures d'exploitation) certains travaux d'entretien.:

### ■ Nettoyage des lames de courant aux roues:

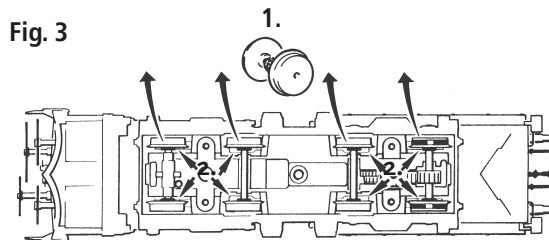
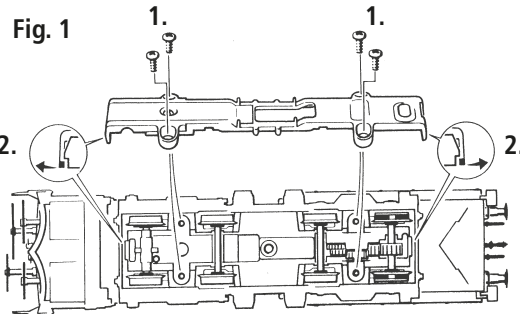
Les lames de contacts risquent de s'encrasser rapidement sur des voies poussiéreuses. Veuillez enlever la poussière aux endroits marqués à la fig. 3 à l'aide d'un petit pinceau souple. Dé montez d'abord le couvercle du carter des engrenages (fig. 1).



72806



## ■ Lubrification

Dé montez d'abord le couvercle du carter des engrenages (fig. 1).  
N'appliquez qu'une toute petite goutte aux endroits indiqués par le plan de graissage (fig. 2).

Nous conseillons l'huileur **ROCO**, art. n° 10906.

Fig. 2

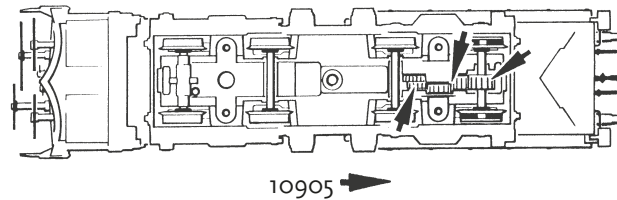
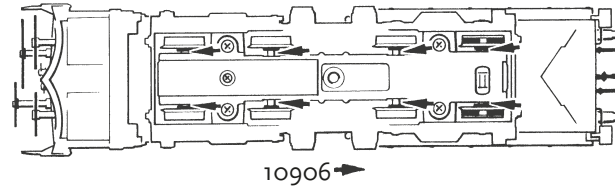

Pour lubrifier les éléments de l'entraînement (pignons, vis sans fin) nous vous conseillons la **graisse spéciale ROCO 10905**. En cas de lubrification, ne pas huiler ces éléments.

F

72806





F

### ■ Échange des bandages d'adhérence

Dé montez d'abord le couvercle du carter des engrenages (fig. 1). Délogez ensuite les essieux bandagés et enlevez, à l'aide d'une aiguille ou d'un tournevis fin, les bandages d'adhérence (fig. 4).

Lors du montage des nouveaux bandages veuillez veiller à ce que les bandages ne soient pas tor-dues.

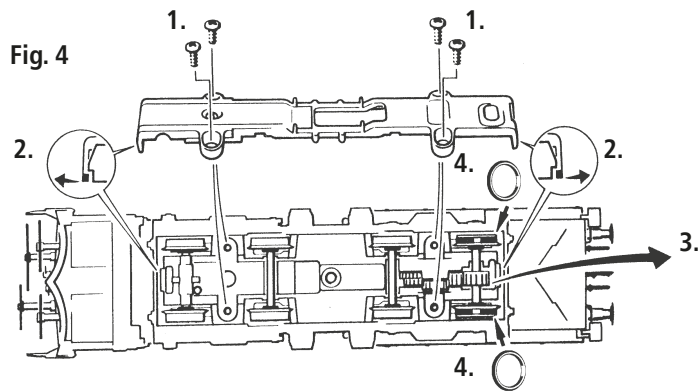

### ■ Fotteur pour Systeme AC

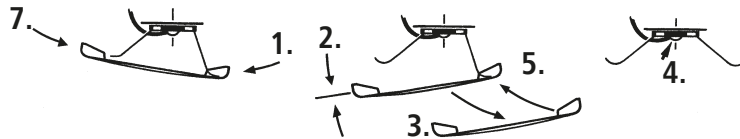

## Aperçu des fonctions

### ■ Affectation des touches de fonction

Le décodeur a été programmé, en usine, à l'adresse 03.

| F-Goût | Fonction                  |
|--------|---------------------------|
| F0     | Eclairage                 |
| F1     | Bruitage                  |
| F2     | Fraise                    |
| F3     | Lever fraise              |
| F4     | Tourner superstructure    |
| F5     | Trompe                    |
| F6     | Vitesse de manœuvre       |
| F7     | Eclairage marche          |
| F8     | Signal d'alarme éclairage |
| F9     | Ditch-Lights              |
| F10    | Trompe                    |

| F-Goût | Fonction  |
|--------|---|
| F11    | Sablage   |
| F12    | Lumière arrière   |
| F13    | Grincement de virages (uniquement avec F1 et en marche) |
| F14    | Touche muette   |
| F15    | Volume +  |
| F16    | Volume -  |

 **Eclairage rouges sans fonction!**

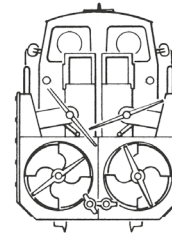

F0 Eclairage



F9 Ditch-Lights

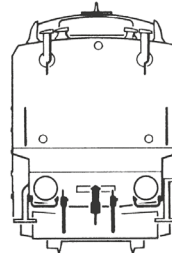

F12 Lumière arrière



F8 Signal d'alarme éclairage



F

72806





F

F2 Fraise

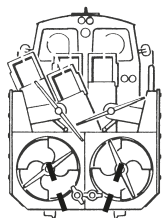

F2

F4 Tourner superstructure 180°

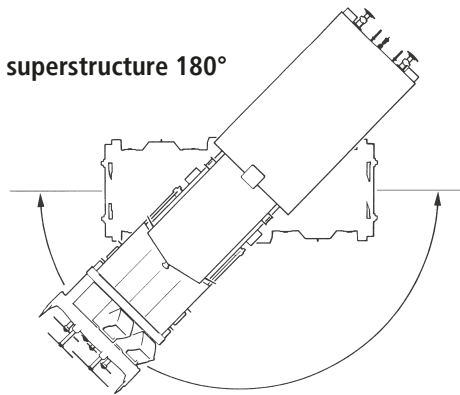

72806

F3 Lever fraise

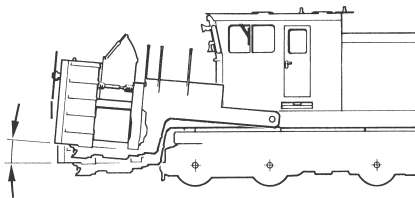

F7 Eclairage marche

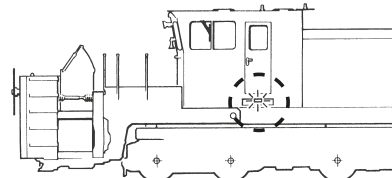



## Le décodeur-son

F

### ■ Réglages de la locomotive

Le décodeur-son contenu dans cette locomotive a été ajusté de façon optimale sur la locomotive. Cependant, vous pouvez modifier de nombreuses caractéristiques du décodeur selon vos désirs. Pour cela, il est possible de modifier certains paramètres (appelés aussi CV – Configuration Variable- ou registres). Veuillez cependant vérifier avant chaque programmation si celle-ci est effectivement nécessaire. Si les réglages sont faux, il se peut que le décodeur ne réagisse plus correctement.

Pour un grand confort de conduite, le décodeur a un préréglage standard de 28/128 crans de marche. Ainsi, il est utilisable avec tous les boîtiers de commande modernes DCC (Z21® système MULTIMAUS®) et Motorola®.



Le décodeur-son de la locomotive a été spécialement modifié pour les fonctions supplémentaires et ne doit pas être échangé contre un décodeur disponible dans le commerce.



Si la locomotive doit être à nouveau programmée, seule la locomotive doit se situer sur le rail de programmation.

72806

## ■ Liste CV

F

| CV | Nom   | Valeurs ajustables | Valeurs standard |
|----|---|--------------------|------------------|
| 1  | <b>Adresse</b> (= courte adresse)   | 01 – 99            | 3                |
| 2  | <b>Tension de démarrage</b> (vitesse de fluage la plus petite)  | 01 – 255           | 4                |
| 3  | <b>Temps d'accélération</b> (de l'arrêt jusqu'à la vitesse maximale)  | 00 – 255           | 12               |
| 4  | <b>Temps de freinage</b> (de la vitesse maximale jusqu'à l'arrêt)   | 00 – 255           | 14               |
| 5  | <b>Vitesse maximale</b>   | 00 – 255           | 255              |
| 6  | <b>Vitesse moyenne</b> (Définition de la vitesse moyenne entre seuil de démarrage et vitesse maximale)<br>La valeur 1 équivaut à 1/3 de Vmax. (CV5)   | 00 – 252           | 1                |
| 7  | <b>N° de la version du logiciel du décodeur</b> uniquement en lecture! Possible uniquement avec des centrales et amplificateurs bidirectionnels)<br><b>Important !</b> Pour l'utilisation de la Z21 / multiMAUS afin d'atteindre des CV supérieures à CV255 : avec la programmation à court terme de la CV7, seul l'accès de programmation correspondant avec la valeur 10 peut augmenter de 100 emplacements CV (CV166 a ainsi accès à CV266 par exemple !), la valeur 20 peut augmenter de 200 emplacements CV. |                    |                  |
| 8  | <b>Fonction Reset</b> Initialisation de toutes les valeurs à l'état standard; (le code du constructeur est lisible sur les amplificateurs/centrales capables de décoder)  |                    | 08 = Reset       |

| CV        | Nom   | Valeurs ajustables | Valeurs standard |
|-----------|---|--------------------|------------------|
| 13        | <p><b>Mode «commande analogue» des fonctions «F1» à F8</b> e variable programmée à la valeur «00», aucune fonction n'est activée)</p> <p>01 – Fonction F1      02 – Fonction F2      04 – Fonction F3      08 – Fonction F4<br/> 16 – Fonction F5      32 – Fonction F6      64 – Fonction F7      128 – Fonction F8</p> <p><b>Attention !</b> En activant plusieurs fonctions par leurs variables CV respectives en vue d'une exploitation en commande analogue les différentes fonctions ainsi activées seront exécutées simultanément.</p> | 00 – 255           | 1                |
| 14        | <p><b>Analogue modes F9 - F12</b></p> <p>01 – Locomotive headlight (front)   02 – Locomotive headlight (rear)   04 – Fonction F9<br/> 08 – Fonction F10   16 – Fonction F11   32 – Fonction F12</p>   | 00 – 255           | 195              |
| 17+<br>18 | <b>Adresse longue</b> (Condition préalable : l'adresse longue est activée conformément au réglage CV29)   | 100 – 9999         |                  |
| 29        | <b>Réglages</b>   |                    | 14               |
| 266       | <b>Réglage globale de l'intensité de tous les bruits</b> (prière de bien vérifier la programmation des variables CV 121 à 123!)   | 00 – 255           | 55               |
| 287       | <b>Seuil d'activation du bruit de freinage</b> (valeur 00 = Les bruits du freinage ne s'activent que machine déjà à l'arrêt)  | 00 – 255           | 20               |





## ■ Système avec centrale DCC (Z21® système MULTIMAUS®)

F

Etant donné que la (MULTIMAUS®), dispose de 20 touches de fonction dont une touche pour l'éclairage, l'utilisation de l'ensemble du kit est ainsi d'une grande facilité.

### Types de programmation

**Notre recommandation** : programmation CV directe (type octet) ou mode POM (programmation sur le rail principal).

La programmation est décrite dans le manuel de la MULTIMAUS®.

72806  
III  
II  
I

### Lecture :

Vous pouvez lire les valeurs de type octet ou bit avec un équipement approprié (par exemple Z21® / z21® / z21® start).

## ■ Fonction complémentaire

Vous pouvez télécharger ce manuel par Internet à l'adresse MX645P22 [www.zimo.at](http://www.zimo.at) comme document.





## Notizen / Notes

F





D  
GB  
F

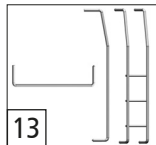
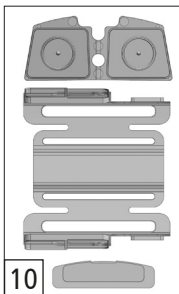
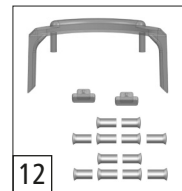
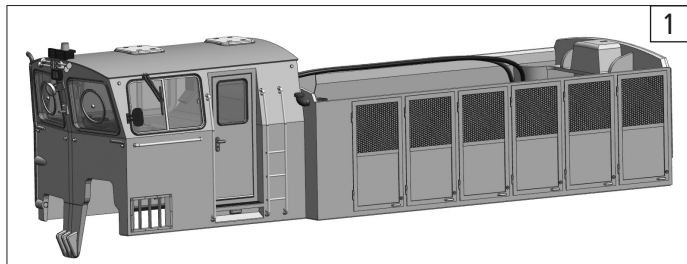
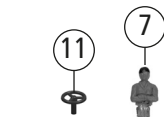
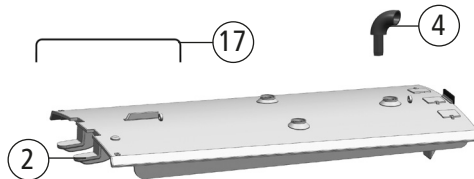
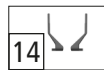
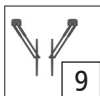
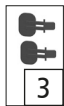
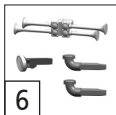

72806

Symbolische Darstellung / Symbolic Illustration / Illustration figurative



| Pos. Nr. / Pos.no. | Beschreibung / Description                                 | Art.-Nr. / Art.no. | Preisgruppe /Price bracket |
|--------------------|--|--------------------|----------------------------|
| 1                  | Gehäuse kpl. BNSF 972558 / Body ass. BNSF 972558           | 143389             | 37                         |
| 2                  | Dach lackiert m. Hebeösen / Painted roof with lifting lugs | 143387             | 14                         |
| 3                  | Rückspiegel / Rear-view mirror                             | 143209             | 8                          |
| 4                  | Auspuff / Exhaust  | 143201             | 3                          |
| 5                  | Zusatzscheinwerfer / Additional lights                     | 143206             | 3                          |
| 6                  | TS - Gehäuse / Parts set body                              | 143393             | 10                         |
| 7                  | E-Lokführer / E-train driver                               | 110407             | 6                          |
| 8                  | Stirnlichtring / Rear headlight ring                       | 135068             | 5                          |
| 9                  | TS - Scheibenwischer / Window wiper                        | 135065             | 19                         |
| 10                 | TS - Fenster / Parts set - Window                          | 143392             | 12                         |
| 11                 | Handrad Führerstand / Driver stand hand wheel              | 143391             | 3                          |
| 12                 | Lichtleiter / Light conductor                              | 135051             | 9                          |
| 13                 | TS - Griffstangen / Parts set – Handle bars                | 143382             | 15                         |
| 14                 | TS - Scheibenwischer hinten / Window wiper rear            | 139788             | 11                         |
| 15                 | GF-Schraube M1,6x4 / GF-screw M1,6x4                       | 114850             | 3                          |
| 16                 | Blinklicht / Turn signal                                   | 143199             | 3                          |
| 17                 | Dachgriff / Roof handrail                                  | 143388             | 3                          |
| 18                 | Platine für Blinklicht / Printed circuit for turn signal   | 143211             | 11                         |
| 19                 | Auspuff / Exhaust  | 143390             | 4                          |
| 20                 | Sockeldach / Socket roof                                   | 143394             | 6                          |









D

GB

F

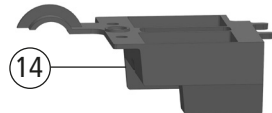
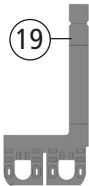
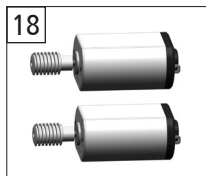
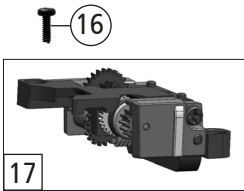
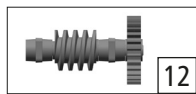
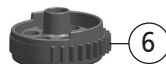
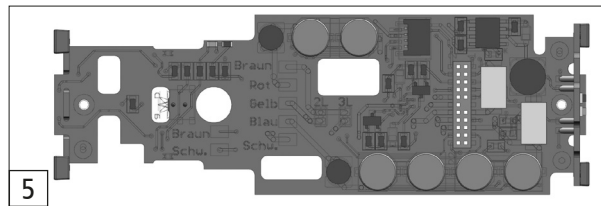
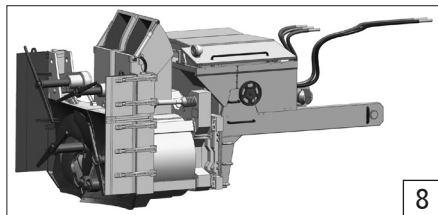
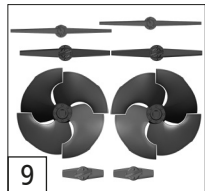
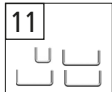
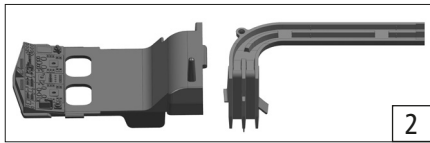
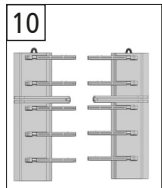
72806



Symbolische Darstellung / Symbolic Illustration / Illustration figurative





| Pos. Nr. / Pos.no. | Beschreibung / Description                                   | Art.-Nr. / Art.no. | Preisgruppe /Price bracket |
|--------------------|--|--------------------|----------------------------|
| 1                  | Handrad / Handwheel  | 143378             | 4                          |
| 2                  | TS-Führerstand / Part set drivers cab                        | 143203             | 9                          |
| 3                  | GF-Schraube M1,6x4 / GF-screw M1,6x4                         | 114850             | 3                          |
| 4                  | Sounddecoder 22 Plux / Sound plug decoder - 22 Plux          | 129000             | 39                         |
| 5                  | Platine kpl. / Circuit board, complete                       | 143188             | 34                         |
| 6                  | Zahnkranz / Sprocket   | 143376             | 4                          |
| 7                  | Schraube 1,5x5 / Screw 1,5x5                                 | 108137             | 3                          |
| 8                  | Vorbau kpl. / Front end, complete                            | 143377             | 36                         |
| 9                  | TS - Vorbau / Parts set – Front end                          | 143379             | 9                          |
| 10                 | TS-Schaufelblech / Shovel panel left and right               | 143380             | 15                         |
| 11                 | TS-Tritte / Part set steps                                   | 143381             | 11                         |
| 12                 | Schneckensatz kpl. / Worm set, complete                      | 136645             | 10                         |
| 13                 | SK-Schraube M1,6x4 / SK-screw M1.6x4                         | 115161             | 3                          |
| 14                 | Lautsprecherbox / Loudspeaker box                            | 143193             | 6                          |
| 15                 | Lautsprecher / Loudspeaker                                   | 129524             | 14                         |
| 16                 | GF-Schraube M2x5 / GF-screw M2x5                             | 114966             | 3                          |
| 17                 | Getriebe kpl. o. Motoren / Transmission, compl. w/o motors   | 135046             | 24                         |
| 18                 | Motoren für Doppelgetrieb / Motors for twin transmission     | 135048             | 19                         |
| 19                 | Flexleiter Doppelgetriebe / Twin transmission flex conductor | 135047             | 12                         |
| 20                 | Schraube M1,4x4 / Screw M1.4x4                               | 127203             | 3                          |

D  
GB  
F

72806  
III  
IV  
V



D

GB

F

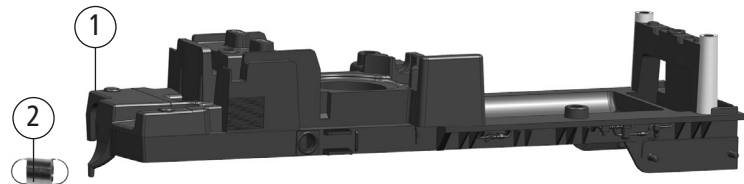

72806

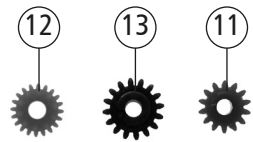
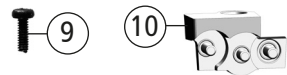
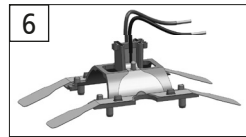
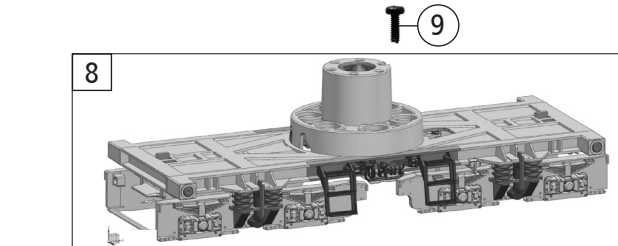

Symbolische Darstellung / Symbolic Illustration / Illustration figurative



| Pos. Nr. / Pos.no. | Beschreibung / Description                                | Art.-Nr. / Art.no. | Preisgruppe /Price bracket |
|--------------------|---|--------------------|----------------------------|
| 1                  | Rahmen lackiert u. bedruckt / Frame, painted and printed  | 143384             | 17                         |
| 2                  | Zugfeder / Spring   | 86208              | 3                          |
| 3                  | TS-Kasten / Part set box                                  | 143385             | 5                          |
| 4                  | Antriebsatz / Drive kit                                   | 136646             | 6                          |
| 5                  | GF-Schraube M1,6x4 / GF-screw M1,6x4                      | 114850             | 3                          |
| 6                  | Kontakthalter kpl. / Contact holder, complete             | 143372             | 13                         |
| 7                  | Motor / Motor   | 135034             | 28                         |
| 8                  | Drehgestellblende m. Kontakte / Bogie frame with contacts | 143369             | 20                         |
| 9                  | GF-Schraube M2x5 / GF-screw M2x5                          | 114966             | 3                          |
| 10                 | Getriebeeinsatz / Transmission insert                     | 135030             | 8                          |
| 11                 | Zahnrad Z=14 - rot / Gear Z=14                            | 86480              | 3                          |
| 12                 | Zahnrad Z=20/10 M=0.3/0.4 / Gear Z=20/10                  | 86462              | 8                          |
| 13                 | Zahnrad Z=16 - schwarz / Gear Z=16                        | 117617             | 3                          |
| 14                 | Kadeeabdeckung / Kadeec over                              | 143386             | 3                          |
| 15                 | Kadeekupplung / Kadee coupler                             | 143197             | 13                         |
| 16                 | Drehgestelleitung / Bogieline                             | 143374             | 3                          |

D

GB

F

72806





D

GB

F

72806

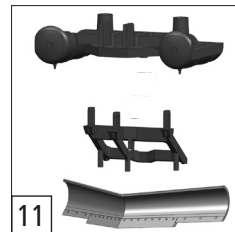
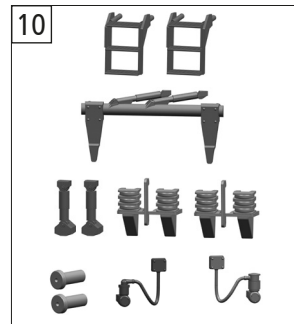
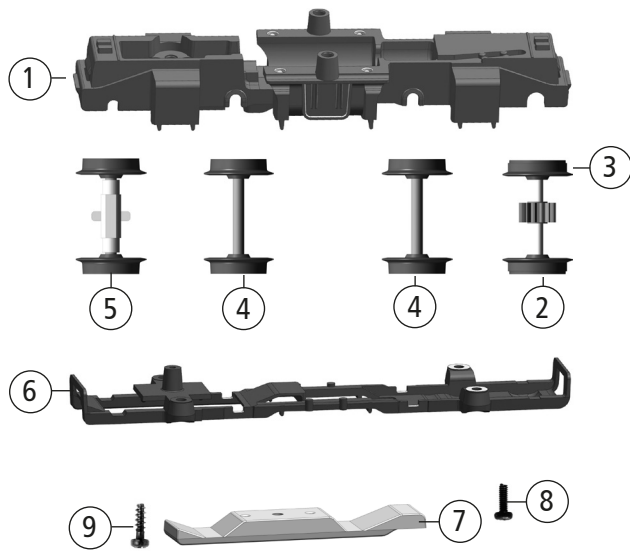

Symbolische Darstellung / Symbolic Illustration / Illustration figurative



| Pos. Nr. / Pos.no. | Beschreibung / Description  | Art.-Nr. / Art.no. | Preisgruppe /Price bracket |
|--------------------|---|--------------------|----------------------------|
| 1                  | Fahrgestell lackiert / Painted chassis                              | 143368             | 11                         |
| 2                  | Radsatz m. 2Hafr.+Zahn. / Wheel set w. 2 fastening rings+gear       | 143183             | 12                         |
| 3                  | Hafringe 10,5-13,5 - 10 Stk. / 10.5-13.5 fastening rings - 10 pcs.  | 133238             | 10                         |
| 4                  | Radsatz o. Hafr. o. Zahn. / Wheel set w.o. fastening ring or gear   | 143184             | 10                         |
| 5                  | Radsatz m.Pendelachse o.ZR/HR. / Wheel set w. swing axle, w.o. gear | 143185             | 11                         |
| 6                  | Getriebeboden / Transmission base                                   | 143373             | 5                          |
| 7                  | DC-Platte / DC board  | 143375             | 10                         |
| 8                  | GF-Schraube M1,6x4 / GF-screw M1,6x4                                | 114850             | 3                          |
| 9                  | Schraube 1,5x5 / Screw 1,5x5  | 108137             | 3                          |
| 10                 | TS - Drehgestellblende / Parts set - Bogie frame                    | 143370             | 8                          |
| 11                 | TS - Schneepflug / Parts set – Snowplough                           | 143383             | 6                          |
| 12                 | Fixierungen - Glasbox o. Abb. / Fixations - glass box no ill.       | 96315              | 12                         |
| 13                 | Glasbox o. Abb. / Glass box no ill.                                 | 96233              | 11                         |
| 14                 | Schiene - Glasbox o. Abb. / Rail - glass box no ill.                | 96232              | 11                         |







## Notizen / Notes





## Notizen / Notes

---

---

---

---

---





Bitte bewahren Sie die Verpackung des Modells sorgfältig auf. Beim Abstellen des Modells bietet sie den besten Schutz. Ein mit beigelegten Zurüstteilen aufgerüstetes Modell paßt nur bedingt wieder in die Originalverpackung hinein, da diese aus Gründen der Transportsicherung sehr eng sein muß. Kleinere Teile des Modells, wie z.B. Puffer, sind wegen Detailtreue als aufgerüstete Steckteile ausgeführt und sind daher mit dem Grundkörper nicht ganz fest verbunden. Beim selbstverschuldeten Verlust möchten Sie bitte ein solches Teil neu bestellen. (In diesem Fall können Sie diese Teile auf dem Ersatzteilweg nachbestellen, eine Reklamation kann nicht geltend gemacht werden.) **Achtung!** Bei unsachgemäßem Gebrauch besteht Verletzungsgefahr durch funktionsbedingte scharfe Kanten und Spitzen! Änderungen von Konstruktion und Ausführung vorbehalten!

Don't throw your box in the dustbin. If your model is not in use this box will keep it safe. If kits are mounted on a wagon it will be slightly tight when placing it in the original box. This guarantees safe transport. To keep the model like the original, smaller parts (e.g. buffers) had been manufactured separately from the body and are not tightly fixed on it. Therefore they probably can get lost. In this case you certainly may reorder them but a complaint would not be acceptable. **Attention!** At an incorrect use there exists danger of hurting because of cutting edges and tips! We reserve the right to change the construction and design!

Veuillez conserver ce mode d'emploi ainsi que l'emballage en vue d'un futur emploi. L'emballage se prête particulièrement bien pour stocker et protéger votre modèle lorsqu'il n'est pas en service. Un wagon entièrement équipé de ses pièces de finition ne rentre plus dans son emballage qu'après avoir dégagé la place nécessaire à l'aide d'un couteau fin et bien guisé aux endroits où sont montés ces pièces. La stabilité et la sécurité de l'emballage lors du transport du modèle de l'usine à votre détaillant (ou même à vous) impose une réduction au strict minimum de toute place découpée et non utilisée, raison pour laquelle ces d'coupes ne peuvent malheureusement pas être aménagées déjà en usine. Quelques petites pièces de finition (des tampons p. e.) ne sont pas moulées d'un seul bloc avec leurs bases, mais séparément rapportées en vue d'une réalisation plus détaillée. Cela implique le risque de perte de ces composants. Dans ce cas, vous pouvez commander ces pièces aux S.A.V. ROCO; nous ne pouvons cependant pas donner suite à une réclamation éventuelle à cause de ces pièces perdues. **Attention!** Il y a danger de blessure à un emploi incorrect à cause des aiguilles et arêtes vives! Nous reservons le droit de modifier la construction et le dessin!



Modelleisenbahn GmbH

A-5101 Bergheim  
Plainbachstraße 4

Email: roco@roco.cc

Tel.: 00800 5762 6000   
(kostenlos/ free of charge/ gratuit)

International: +43 820 200 668  
(kostenpflichtig / chargeable / avec des  
coûts - Zum Ortstarif aus dem Festnetz /  
local tariff for landline / prix d'une appel  
locale depuis du téléphone fixe - Mobil-  
funk / Mobile max. 0,42€/min. incl. VAT)



8072806920 IX / 2019

[www.roco.cc](http://www.roco.cc)